

Turb[®] 750 IR/T

LAB TURBIDIMETER



a xylem brand

Copyright © 2022 Xylem Analytics Germany GmbH
Printed in Germany.

Contents

1	Overview	6
1.1	General features	6
1.2	Keypad	7
1.3	Display	8
1.4	Socket field	8
2	Safety	9
2.1	Safety information	9
2.1.1	Safety information in the operating manual	9
2.1.2	Safety signs on the meter	9
2.1.3	Further documents providing safety information	9
2.2	Safe operation	10
2.2.1	Authorized use	10
2.2.2	Requirements for safe operation	10
2.2.3	Unauthorized use	10
3	Commissioning	11
3.1	Scope of delivery	11
3.2	Power supply	11
3.2.1	Inserting the batteries	11
3.2.2	Connecting the power pack	12
3.3	Initial commissioning	12
4	Operation	13
4.1	Switching on the meter	13
4.2	Inserting a cell	13
4.3	Preparing the cell and sample	14
4.3.1	Preparing the cell	14
4.3.2	Preparing the sample	16
4.4	General operating principles	16
4.4.1	Operating modes	16
4.4.2	Navigation	16
4.4.3	Navigation example 1: Setting the language	18
4.4.4	Example 2 on navigation: Setting the date and time	19
4.4.5	Example 3 on navigation: Entering numerals and text	21
4.5	System settings (<i>System</i> menu)	26
4.5.1	<i>Measured value memory</i>	26
4.5.2	<i>Display</i>	27
4.5.3	<i>Interface</i>	28
4.5.4	<i>Date/time</i>	28
4.6	Measuring the turbidity	29
4.6.1	Settings for turbidity measurement	31
4.7	Calibration	31
4.7.1	Settings for calibration	32
4.7.2	Carrying out a calibration	33

4.8	Analytical quality assurance (AQA)	36
4.8.1	General information	36
4.8.2	Settings for quality assurance (AQA)	36
4.8.3	Carrying out the AQA check	37
4.9	Memory	39
4.9.1	Storing measurement datasets	39
4.9.2	Filtering measurement datasets	40
4.9.3	Displaying measurement datasets	41
4.9.4	Outputting measurement datasets to the interfaces	42
4.9.5	Erasing stored measurement datasets	42
4.10	Transmitting data	42
4.10.1	Establishing the connection to a PC	42
4.10.2	Data transmission with the PC software Turb® Data	43
4.10.3	Data transmission with the Excel add-in MultiLab® Importer	43
4.10.4	Configuration for the data transmission to a terminal program	44
4.10.5	Establishing the connection to a printer	45
4.10.6	Starting the data transmission at the Turb® 750 IR/T (at MultiLab® Importer, printer, terminal program	45
4.10.7	Examples of data transmitted (printer, terminal program)	46
4.11	Reset	47
4.11.1	Resetting the system settings	47
4.11.2	Resetting turbidimeter settings	48
4.12	Meter information	49
4.13	Software update	49
5	Maintenance, cleaning	50
5.1	Maintenance	50
5.2	Cleaning	50
5.2.1	Cleaning the cell shaft	51
5.2.2	Cleaning the cells	51
5.3	Packing	51
6	What to do if...	52
6.1	General information	52
6.2	Turbidity	53
7	Technical data	54
7.1	General data	54
7.2	Turbidity	55
7.2.1	Turb® 750 IR	55
7.2.2	Turb® 750 T	56
8	Accessories and options	58
9	Firmware update	59
10	Disposal	60

11 Lists 61
12 Index 63

1 Overview

1.1 General features

The compact Turb® 750 IR/T precision lab turbidimeter enables you to carry out turbidity measurements quickly and reliably.

The Turb® 750 IR/T lab turbidimeter provides the maximum degree of ease of operation, reliability and measuring certainty for all applications.

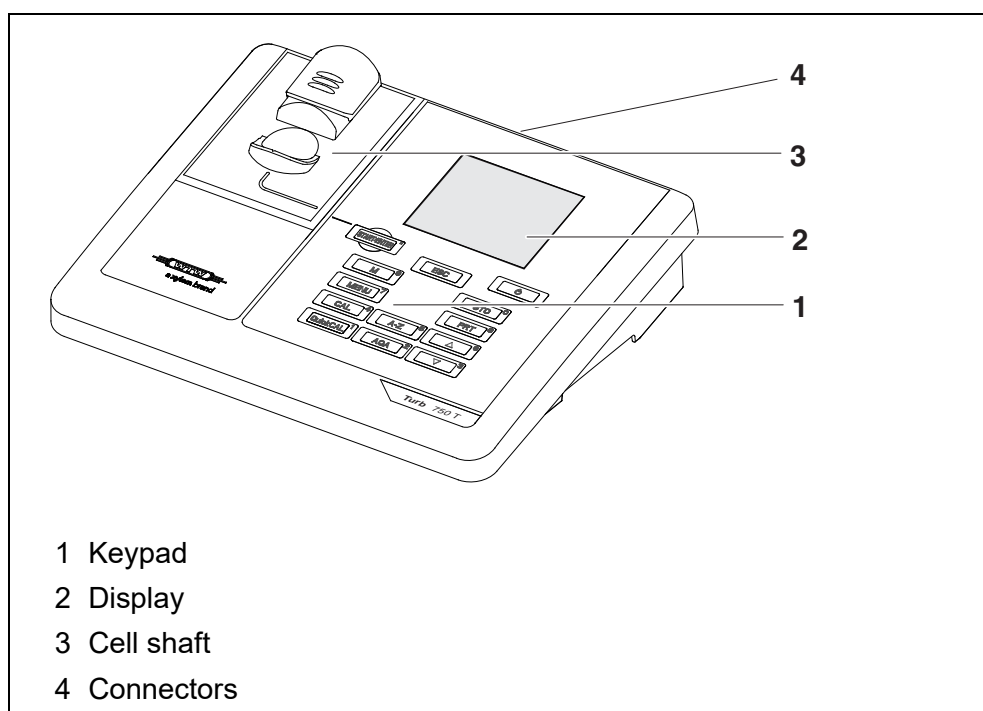

If you need further information or application notes, you can obtain the following material from WTW:

- Application reports
- Primers
- Safety datasheets.

You will find information on available literature in the WTW catalog or on the Internet at www.xylyanalytics.com.

1.2 Keypad

In this operating manual, keys are indicated by brackets <.> .
The key symbol (e.g. <STO⁽⁰⁾>) generally indicates a short keystroke (under 2 sec) in this operating manual. A long keystroke (approx. 2 sec) is indicated by the underscore behind the key symbol (e.g. <STO⁽⁰⁾_>).

Key functions	Key	Description
	<M ⁽⁹⁾ >	Switch to the measured value display
	<CAL ⁽⁴⁾ >	Start calibration
	<QuickCAL ⁽¹⁾ >	Start simplified calibration with one standard.
	<AQA ⁽²⁾ >	Start the checking of the meter with AQA standards The key is only active if any AQA checks were activated.
	<A-Z ⁽⁵⁾ _>	Select the entry mode in an entry field Numerical or alphanumeric entry
	<A-Z ⁽⁵⁾ >	Display the next digit in an entry field with active alphanumeric entry (same function as <▲ ⁽⁶⁾ >)
	<START/ENTER ^(.) >	Open menus / confirm entries / start measurement
	<MENU ⁽⁷⁾ >	Call up the <i>Configuration</i> menu (all settings are made here)
	<On/Off>	Switch the meter on or off
	<PRT ⁽⁸⁾ >	Output display contents to RS232 or USB interface (e.g. print)
	<STO ⁽⁰⁾ >	Open the <i>Store</i> menu: <STO ⁽⁰⁾ > Quick storing: 2 x <STO ⁽⁰⁾ >
	<STO ⁽⁰⁾ _>	Open the measured value memory
	<▲ ⁽⁶⁾ >, <▼ ⁽³⁾ >	Highlight menu items or selection; Set values
	<ESC>	Switch to the next higher menu level / cancel input



Entering numerals with the number keys (see EXAMPLE 3 ON NAVIGATION: ENTERING NUMERALS AND TEXT, page 21).

1.3 Display

The graphic display shows all information of the current measurement in the measured value display. The illumination enables to read the display even in the dark.

Example

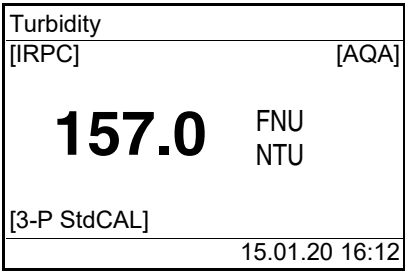

The screenshot shows a digital display for Turbidity. At the top, it says "Turbidity". Below that, there are two status indicators: "[IRPC]" on the left and "[AQA]" on the right. The main display area shows a large number "157.0" followed by "FNU" and "NTU" on separate lines. Below the main display, there is another status indicator "[3-P StdCAL]". At the bottom of the display, it shows the date and time "15.01.20 16:12". Four arrows point to these elements: 1 points to the top status indicators, 2 points to the measured value, 3 points to the calibration status indicator, and 4 points to the date and time.

- 1 Status display indicators, e.g.:
[IRPC] = Intelligent reproducibility and plausibility check
[AQA] = Valid AQA check available
- 2 Measured value (with unit)
- 3 Status display indicators, e.g.
[3-P StdCAL] = Valid calibration available
(calibration type: 3-P StdCAL)
- 4 Status line with date and time

1.4 Socket field

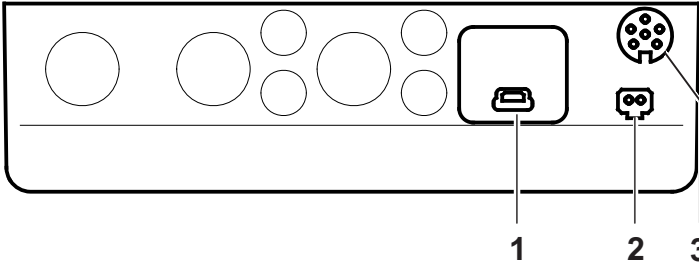

The diagram shows a horizontal row of three sockets. From left to right: a USB-B (micro) interface, a Power pack socket, and an RS232 (serial) interface. Each socket is labeled with a number 1, 2, or 3 respectively.

- 1 USB-B (micro) interface
- 2 Power pack
- 3 RS232 (serial) interface



Only one cable may be connected to an interface (RS232 or USB) at a time.

2 Safety

2.1 Safety information

2.1.1 Safety information in the operating manual

This operating manual provides important information on the safe operation of the meter. Read this operating manual thoroughly and make yourself familiar with the meter before putting it into operation or working with it. The operating manual must be kept in the vicinity of the meter so you can always find the information you need.

Important safety instructions are highlighted in this operating manual. They are indicated by the warning symbol (triangle) in the left column. The signal word (e.g. "CAUTION") indicates the level of danger:



WARNING

indicates a possibly dangerous situation that can lead to serious (irreversible) injury or death if the safety instruction is not followed.



CAUTION

indicates a possibly dangerous situation that can lead to slight (reversible) injury if the safety instruction is not followed.

NOTE

indicates a possibly dangerous situation where goods might be damaged if the actions mentioned are not taken.

2.1.2 Safety signs on the meter

Note all labels, information signs and safety symbols on the meter and in the battery compartment. A warning symbol (triangle) without text refers to safety information in this operating manual.

2.1.3 Further documents providing safety information

The following documents provide additional information, which you should observe for your safety when working with the measuring system:

- Operating manuals of further accessories
- Safety datasheets of calibration or maintenance accessories (such as buffer solutions, electrolyte solutions, etc.)

2.2 Safe operation



CAUTION

Danger of eye damage by visible and invisible LED radiation. In the cell shaft of the Turb® 750 IR there are light emitting diodes (LEDs) of the 1M class.

Do not look at the radiation using optical instruments. With normal, authorized use there is no hazard.

2.2.1 Authorized use

This meter is authorized exclusively for turbidity measurements in the laboratory.

Only the operation and running of the meter according to the instructions and technical specifications given in this operating manual is authorized (see chapter 7 TECHNICAL DATA).

Any other use is considered unauthorized.

2.2.2 Requirements for safe operation

Note the following points for safe operation:

- The meter may only be operated according to the authorized use specified above.
- The meter may only be supplied with power by the energy sources mentioned in this operating manual.
- The meter may only be operated under the environmental conditions mentioned in this operating manual.
- The meter may only be opened if this is explicitly described in this operating manual (example: Inserting the batteries).

2.2.3 Unauthorized use

The meter must not be put into operation if:

- it is visibly damaged (e.g. after being transported)
- it was stored under adverse conditions for a lengthy period of time (storing conditions, see chapter 7 TECHNICAL DATA).

3 Commissioning

3.1 Scope of delivery

- Lab turbidimeter Turb[®] 750 IR or Turb[®] 750 T
- 4 batteries 1.5 V type AA
- Power pack with Euro plug and exchange plugs for USA, UK, and Australia
- Cable USB-A to USB-B (micro)
- 6 empty cells 28 mm with label to mark the cell
- AMCO[®]-Clear turbidity standard
- Microfiber cloth to clean the meter
- Compact operating manual and short operating manual
- CD-ROM with detailed operating manual
- CD-ROM with software Turb[®] Data

3.2 Power supply

The Turb[®] 750 IR/T is supplied with power by the power pack included in the scope of delivery. The batteries (4 batteries 1.5 V Mignon type AA) in the battery compartment supply the integrated clock with power when the power supply is missing.

3.2.1 Inserting the batteries

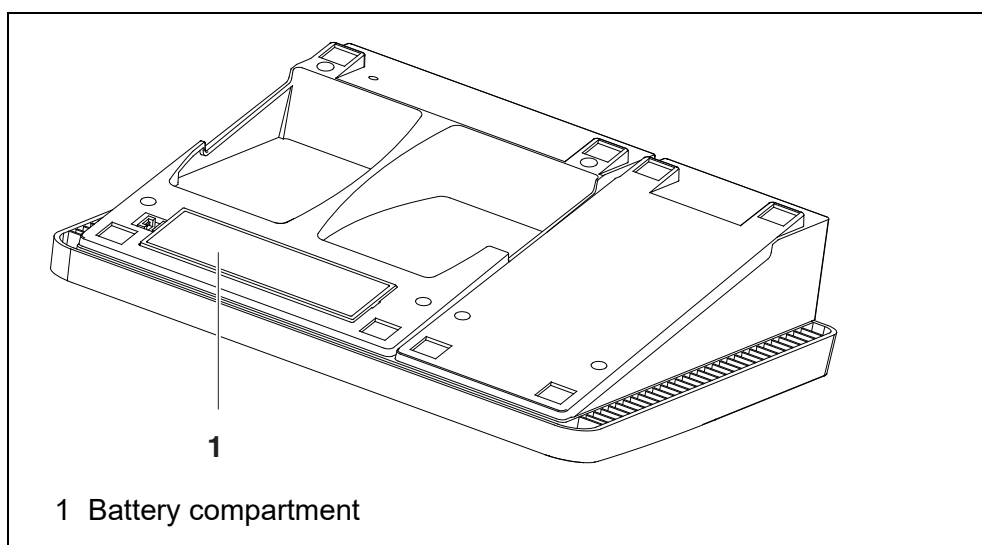

1. Open the battery compartment (1) on the underside of the meter.

2. Place four batteries (type Mignon AA) in the battery compartment.

NOTE

Make sure that the poles of the batteries are positioned correctly. The ± signs on the batteries must correspond to the ± signs in the battery compartment.

3. Close the battery compartment (1).
4. Set the date and time (see section 4.5.5).

3.2.2 Connecting the power pack

**WARNING**

The line voltage at the operating site must lie within the input voltage range of the original power pack (see chapter 7 TECHNICAL DATA).

Use original power packs only (see chapter 7 TECHNICAL DATA).

- 1 If necessary, replace the Euro plug of the power pack with the country-specific plug suitable for your country.
- 2 Insert the plug of the power pack into the socket of the turbidimeter.
- 3 Connect the power pack unit to an easily accessible mains socket.

3.3 Initial commissioning

Perform the following activities:

- Insert the batteries (see section 3.2.1)
- Connect the power pack (see section 3.2.2)
- Set the language as necessary (see section 4.4.3)
- Set the date and time as necessary (see section 4.4.4)



When you set the language, date and time according to the mentioned sections of this operating manual you will quickly become familiar with the simple operation of the Turb® 750 IR/T.

4 Operation

4.1 Switching on the meter

Switching on

Press the **<On/Off>** key.
The *Start* menu appears for 30 seconds.

The status line indicates the meter designation and the version number of the software.

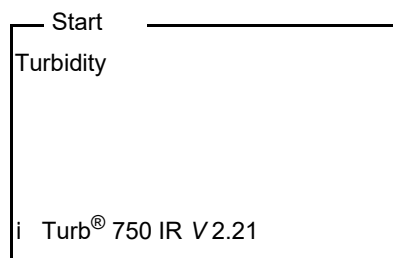

After a few seconds the meter automatically switches to the measuring mode.

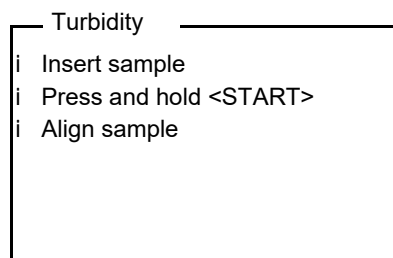

Using **<ESC>**, you can go to the *Start* menu from the measuring mode.

Switching off

Press the **<On/Off>** key.

4.2 Inserting a cell

Before using a cell for the first time, determine and mark the suitable measuring position for the cell (see section 4.3.1).

- 1 Push the dust cover (1) upward.
The cell shaft for 28 mm cells is open.

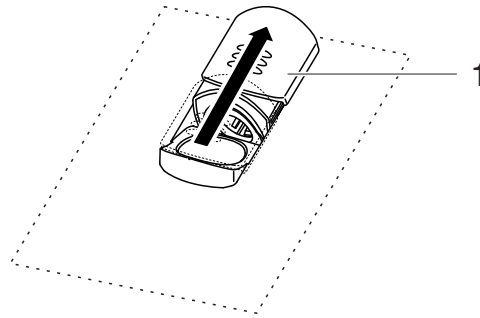

Inserting a 28 mm cell

- 2 Insert the marked cell so that it is positioned on the bottom of the cell shaft.

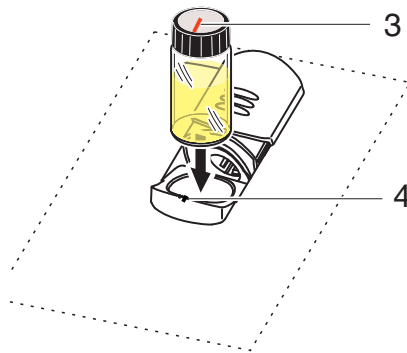

- 3 Align the cell marking (3) with the marking (4) of the cell shaft. The cell is ready to be measured.

4.3 Preparing the cell and sample

Standard solutions and test samples are filled into cells for calibration and turbidity measurement with the Turb® 750 IR/T.

The quality of the measured values depends on the optimum preparation of the cell and sample.

- Preparing the cell (see section 4.3.1)
 - Determine a suitable position in the cell shaft
 - Marking a cell
- Preparing the sample (see section 4.3.2)

4.3.1 Preparing the cell

Even completely clean quality cells exhibit tiny differences in their light trans-

mittance, e.g. inhomogeneities of the glass or small defects (e.g. scratches). Therefore, guidelines for accurate and reproducible measurements (e.g. US EPA) recommend that you always align the cell in the same way for measuring with the aid of arrows printed on or markings. This refers to sample cells and cells for calibration standards.

Prior to using a cell for the first time, the suitable position of the cell in the cell shaft is determined and marked to make sure the optical path is not disturbed. For the following measurements, the cell marking can just be aligned with the meter marking.

The cell marking should be checked regularly and renewed as necessary. The cell can be used until no suitable position for the optical path can be found.



We recommend that you do not treat any scratches in the cell with oily liquids (not even with so-called "special silicone oils"). They could unnecessarily soil the meter and your working environment. The optimum measurement accuracy is ensured by aligning the cells. Scratched cells have to be replaced.

- 1 Clean the cell (see section 5.2.2).
- 2 Stick the label for the marking onto the cell cap.
- 3 Fill the cell with a homogeneous solution (e.g. calibration standard 10.0 NTU).
- 4 Insert the cell (see section 4.2).
- 5
 - Press and keep the **<START/ENTER (.) >** key depressed.
 - Turn the cell slowly and check the measured value:
 - The measured value at the position should be no maximum.
 - At the directly neighboring positions there should not be any sudden changes of the measured values. The deviations of measured values at the neighboring positions should not exceed the following values:
 Measured value < 1 NTU: max. +/- 0.02 NTU
 Measured value > 1 NTU: max. +/- 2 %
- 6 Release the **<START/ENTER (.) >** key.
Measurement starts. The measured value is displayed.

Determining a suitable position in the cell shaft

Marking a cell

- 7 Mark the determined position (aligning) of the cell on the label. The cell is now prepared for all following measuring and calibration actions.

4.3.2 Preparing the sample

Venting the sample

Air bubbles in the sample affect the measuring result to a massive extent because they have a large scattering effect on the incident light. Larger air bubbles cause sudden changes in the measured values whereas smaller air bubbles are recorded by the instrument as turbidity. Therefore, avoid or remove air bubbles:

Avoiding or removing air bubbles

- During sampling, ensure all movement is kept to a minimum
- If necessary, vent the sample (ultrasonic baths, heating or adding a surface-active substance to reduce the surface tension)

4.4 General operating principles

This section contains basic information on the operation of the Turb[®] 750 IR/T.

Operating elements, display

An overview of the operating elements and the display is given in section 1.2 and section 1.3.

Operating modes, navigation

An overview of the operating modes of the Turb[®] 750 IR/T and the navigation through menus and functions can be found in section 4.4.1 and section 4.4.2.

4.4.1 Operating modes

The instrument has the following operating modes:

- Measurement
The display indicates measurement data in the measured value display
- Calibration
The display indicates a calibration procedure with calibration information
- Data transmission
The meter transmits measuring datasets or calibration records to the interface
- Configuration
The display indicates a menu with further menus, settings and functions

4.4.2 Navigation

Measured value display

In the measured value display, open the menu with **<MENU⁽⁷⁾>**.

Menus and dialogs

The menus for settings and dialogs in procedures contain further subelements. The selection is done with the keys **<▲>** **<▼>**.

The current selection is displayed inverse.

- **Menus**

The name of the menu is displayed at the upper edge of the frame. Menus are opened by confirming with **<START/ENTER (.) >**. Example:

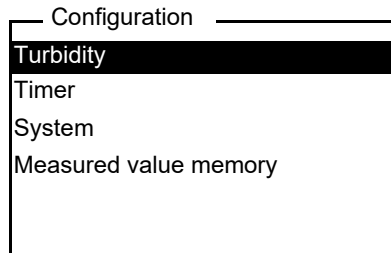

- **Settings**

Settings are indicated by a colon. The current setting is displayed on the right-hand side. With **<START/ENTER (.) >**, the selection of the possible settings is opened. Then the setting can be selected with **<▲>** **<▼>** and confirmed with **<START/ENTER (.) >**.

Example:

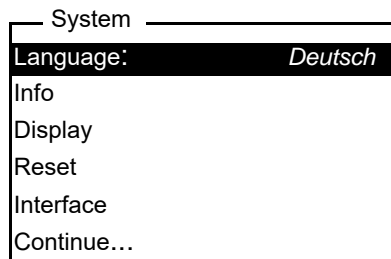

- **Functions**

Functions are designated by the name of the function. They are immediately carried out by confirming with **<START/ENTER (.) >**.

Example: display the *Calibr. record* function (in the *Turbidity* menu).

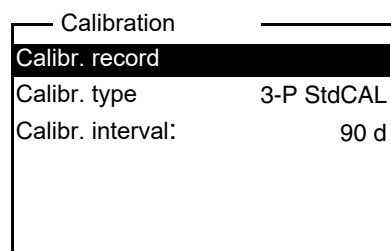

- **Messages**

Information or operating instructions are designated by the *i* symbol. They cannot be selected.

Example:

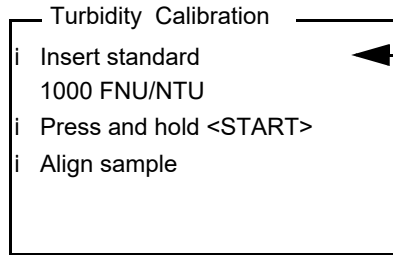

The i indicates info texts, e.g. messages, notes or instructions



The principles of navigation are explained in the two following sections by reference of examples:

- Setting the language (section 4.4.3)
- Setting the date and time (see section 4.4.4).

4.4.3 Navigation example 1: Setting the language



The following example describes in the language of the country how to set the language. On delivery, English is set as the language in the Turb® 750 IR/T. During initial commissioning, you can set the language in the menu, *Configuration / System / Language*.

- 1 In the measured value display:
Open the *Configuration* menu with **<MENU (7) >**.
The instrument is in the configuration mode.
- 2 Select the *System* menu with **<▲> <▼>**.
The current selection is displayed in reverse video.
- 3 Using **<START/ENTER (1) >**, open the *System* menu.
- 4 Select the *Language* menu with **<▲> <▼>**.
The current selection is displayed in reverse video.

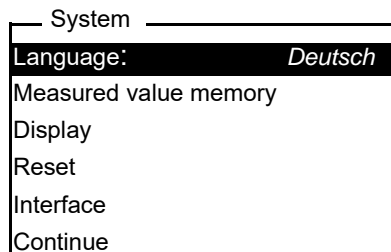

- 5 Open the setting of the *Language* with **<START/ENTER (1) >**.

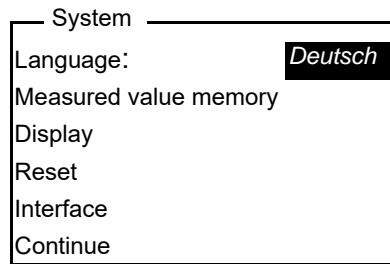

- 6 Select the required language with <▲> <▼>.
- 7 Confirm the setting with <START/ENTER (.) >.
The setting is active. The menu is displayed in the selected language.
- 8 To make further settings, switch to the next higher menu level with <ESC>.

4.4.4 Example 2 on navigation: Setting the date and time

The meter has a clock with a date function. The date and time are indicated in the status line of the measured value display. When storing measured values and calibrating, the current date and time are automatically stored as well.

Numerals are generally entered via the number keys.

The correct setting of the date and time and date format is important for the following functions and displays:

- Current date and time
- Calibration date
- Identification of stored measured values.

Therefore, check the time at regular intervals.



The date and time are reset to default after a fall of the supply voltage (empty batteries).

Setting the date, time and date format

The date format can be switched from the display of day, month, year (*dd.mm.yy*) to the display of month, day, year (*mm/dd/yy* or *mm.dd.yy*).

- 1 In the measured value display:
Open the *Configuration* menu with <MENU (7) >.
The instrument is in the configuration mode.

- 2 Select and confirm the *System / Continue ... / Date/time* menu with **<▲>** **<▼>** and **<START/ENTER (.) >**.

Date/time	
Time:	14:53:40
Date:	15.01.20
Date format:	dd.mm.yy

- 3 Select and confirm the *Time* menu with **<▲>** **<▼>** and **<START/ENTER (.) >**.

A display for the entry of numerals with the number keys opens up.



Keys with additional characters printed on (orange) are assigned doubly. In the input fields you can directly enter digits with the orange number keys.

Time	
<u>1</u> 4:53:40	

- 4 Enter the time using the number keys.
The digit to be changed is displayed underlined.



In the case of wrong entries, you can cancel the procedure with **<ESC>**.

After canceling with **<ESC>**, it is possible to enter all digits once again. The new digits are only taken over by confirming with **<START/ENTER (.) >**.

- 5 Confirm the setting with **<START/ENTER (.) >**.
The time is set.
- 6 Set the current *Date* as necessary. The setting is made similarly to that of the time.
- 7 Change the date format as necessary.

- 8 To make further settings, switch to the next higher menu level with **<ESC>**.
- or
- Switch to the measured value display with **<M⁽⁹⁾>** (short pressure).
The instrument is in the measuring mode.

4.4.5 Example 3 on navigation: Entering numerals and text

Entry fields of the Turb[®] 750 IR/T require different kinds of entries:

- simple numbers (e.g. for entering date and time)
- Numbers with decimal separators (e.g. turbidity setpoints)
- Strings of digits, letters and special characters (e.g. measured value ID)

Entry modes

Two entry modes are available for entering characters.
Up to 12 characters are allowed in entry fields.

Numerical [0-9]

Numerical entry fields:

The numerical entry mode is active.

- Entering digits or numbers:
Press the keys of the numeric keypad (orange)
- Entering decimal separators for numerical values (e.g. turbidity setpoints):
 - Press **<START/ENTER (.)>** once:
The decimal separator is set.
 - Press **<START/ENTER (.)>** twice:
The entry of the numerical digit is completed.
The numerical value is always displayed with decimal places and, if necessary, rounded.
- Changing the entry mode:
Only in entry fields allowing alphanumerical entries: press **<A-Z⁽⁵⁾>** (long keystroke).

Alphanumerical [A-Z]

Alphanumerical entry fields:

The last active numerical entry mode is active.

- Changing the entry mode:
at any time with **<A-Z⁽⁵⁾>** (long keystroke).
The active entry mode is shown on the display.
- Entry of characters (letters, special characters, digits):
Select the characters from the list of available characters :
abcdefghijklmnopqrstuvwxyzABCDEFGHI-
JKLMNOPQRSTUVWXYZ_µ£%&/()[]+-
=.:!/?\$#0123456789

Entering digits

<ESC>	<p>Cancels inputs</p> <ul style="list-style-type: none"> ● 1 x <ESC> The previous entry is erased ● 2 x <ESC> The entry is finished without storing
-------	---

Entry of digits via the number keys (numerical entry mode)

<STO ⁽⁰⁾ >... <M ⁽⁹⁾ >	<p>The digit entry via the keys (orange label with numbers) is active</p>
<START/ENTER ^(.) >	<ul style="list-style-type: none"> ● When entering simple numerals without decimal separators (e.g. date / time): <ul style="list-style-type: none"> – Take over the character string ● When entering numerical values with decimal separators (e.g. turbidity setpoints): <ul style="list-style-type: none"> – Press <START/ENTER^(.)> once: The decimal separator is set. – Press <START/ENTER^(.)> twice: The entry of the numerical digit is completed. The numeric value is always displayed with decimal places and, if necessary, rounded.
<A-Z ⁽⁵⁾ _>	<p>Switch between numerical and alphanumerical entry (if alphanumerical characters are allowed for the entry field)</p>

Entry of letters, special characters, digits via the character list (alphanumerical entry)

<▲ ⁽⁶⁾ >, <A-Z ⁽⁵⁾ >	<p>Display the next character of the list</p>
<▼ ⁽³⁾ >	<p>Display the previous character of the list</p>

<START/ENTER (.)>	Take over the displayed character For the ID selectable characters of the list: abcdefghijklmnopqrstuvwxyzABCDEFGHIJKLM- NOPQRSTUVWXYZ_µ£%&/()[]+- =.:!/?\$#0123456789 Control characters in the list: > : first character in the list take over entire previous string (first character in the list) < : last character in the list erase the last character (last character in the list)
<A-Z (5) _>	Switch between numerical and alphanumerical entry

**Example:
Enter an ID**

- 1 In the measured value display:
Press the **<STO (0) >** key.
The *Store* display appears.

```

Store (996 free)
i 15.01.2020 11:24:16
 16.80 FNU/NTU

assign ID: 0
Store (ID: 0)
  
```

- 2 Open the *assign ID* menu with **<▲>** **<▼>** and **<START/ENTER (.) >**.
The digit that can be edited is shown underlined.

assign ID

[0-9]

0

0_

1

2

3

- 1 Display of the active entry mode:
[0-9] = numerical entry (via the number keys)
[A-Z] = alphanumerical entry (via the list)
- 2 Current ID
- 3 editable ID
(The digit that can be edited is shown underlined.)

- 3 If necessary, erase the ID used last with **<ESC>**.
- 4 If necessary, switch to the alphanumeric entry mode with **<A-Z⁽⁵⁾ _>**.
The entry mode [A-Z] is displayed.
The control character ">" is shown underlined.

assign ID

[A-Z]

0

0>

- 5 Using **<A-Z⁽⁵⁾ >**, **<▲>** **<▼>** and **<START/ENTER^(.) >**, enter an ID consisting of digits, letters or special characters.



If necessary, use **<A-Z⁽⁵⁾ _>** to change the entry mode during the entering.

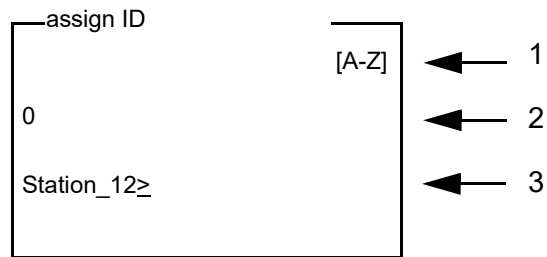

6 Confirm the entered character string with **<START/ENTER (.) >**

7 Using **<START/ENTER (.) >** or **<STO (0) >**, confirm *Store*.

The dataset is stored with the specified ID.

The meter switches to the measured value display.



A measurement dataset is quickly stored by twice pressing **<STO (0) >**. It is stored with the ID last set.

4.5 System settings (System menu)

Settings/functions

The settings are in the menu, *Configuration / System*.
Move to the *Configuration* menu with the **<MENU⁽⁷⁾** > key.

Menu item	Setting	Explanation
<i>Language</i>	<i>Deutsch</i> <i>English</i> <i>Français</i> <i>Español</i>	Select the language (see section 4.4.3)
<i>Info</i>		Information on hardware and software
<i>Display</i>	<i>Illumination</i> <i>Contrast</i> <i>Brightness</i>	Switch on/off the display illumination (see section 4.5.2)
<i>Reset</i>	-	Reset the system settings to the delivery condition (see section 4.11.1).
<i>Interface</i>	<i>Baud rate</i> <i>Output format</i>	Baud rate of the data interface (see section 4.5.3)
<i>Continue ... / Date/time</i>	<i>Time</i> <i>Date</i> <i>Date format</i>	Time and date settings (see section 4.4.4)
<i>Continue ... / Switchoff time</i>	10, 20, 30, 40, 50 min, 1, 2, 3, 4, 5, 10, 15, 20, 24 h	The automatic switchoff function switches the meter off if no entry is made for a specified period of time (<i>Switchoff time</i>). The function is only active with battery operation.
<i>Continue ... / Beep</i>	<i>On</i> <i>Off</i>	Switches on/off the beep on keystroke

4.5.1 Measured value memory

In the *Measured value memory* menu, you find functions to display and edit the stored measurement datasets:

The settings are in the menu, *Configuration / Measured value memory*.
Move to the *Configuration* menu with the **<MENU⁽⁷⁾** > key.

Settings/functions	Menu item	Setting/function	Explanation
	<i>Display</i>	-	<p>Displays in pages all measurement datasets that correspond to the filter settings.</p> <p>Further options:</p> <ul style="list-style-type: none"> ● Scroll through the datasets with <▲> <▼>. ● Output the displayed dataset to the interface with <PRT⁽⁸⁾>. ● Quit the display with <ESC>.
	<i>RS232/USB output</i>	-	<p>Downloads to the interface all measurement datasets that correspond to the filter settings. The download is ordered according to the date and time.</p> <p>The process can take several minutes. To terminate the process prematurely, press <ESC>.</p>
	<i>Data filter</i>	see section 4.9.2	Allows to set filter criteria in order to display and download datasets to the interface.
	<i>Delete</i>	-	<p>Erases the entire contents of the measuring data memory, independent of the filter settings.</p> <p>Note: All calibration data remain stored when this action is performed.</p>

All details on the subjects of memory and stored data are given in section 4.9.2.

4.5.2 Display

In the *Configuration / System / Display* menu, you set the display features: The settings are in the menu, *Configuration / System / Display*. Move to the

Configuration menu with the <MENU ⁽⁷⁾ > key.

Settings	Menu item	Setting	Explanation
	<i>Illumination</i>	<i>Auto off</i>	The automatic switchoff function switches off the display illumination if no key has been pressed for 30 seconds. The function is only active with battery operation.
		<i>On</i> <i>Off</i>	Switches the display illumination on or off permanently
	<i>Contrast</i>	0... 100 %	Changes the display contrast
	<i>Brightness</i>	0... 100 %	Changes the display brightness

4.5.3 Interface

In the *Interface* menu, you set the features of the interface.

The settings are in the menu, *Configuration / System / Interface*. Move to the *Configuration* menu with the <MENU ⁽⁷⁾ > key.

Settings	Menu item	Setting	Explanation
	<i>Baud rate</i>	1200, 2400, 4800, 9600, 19200	Baud rate of the data interface
	<i>Output format</i>	<i>ASCII</i> <i>CSV</i>	Output format for data transmission For details, see section 4.10.6

4.5.4 Date/time

In the *Configuration / System / Continue ... / Date/time* menu, you set the system clock:

The settings are in the menu, *Configuration / System / Continue ... / Date/time*.

Move to the *Configuration* menu with the **<MENU** ⁽⁷⁾ **>** key.

Settings	Menu item	Setting	Explanation
	<i>Time</i>	hh:mm:ss	Enter the time with the number keys
	<i>Date</i>		Enter the date with the number keys
	<i>Date format</i>	<i>dd.mm.yy</i> <i>mm.dd.yy</i> <i>mm/dd/yy</i>	Settings of time and date.

4.6 Measuring the turbidity

NOTE

Never pour any liquids directly into the cell shaft. Always use a cell for measurement. The meter only measures precisely if the cell is closed with the black light protection cap and aligned with the marking of the measuring position determined.



The outside of the cell always has to be clean, dry, and free of fingerprints and scratches. Clean the cells before starting to measure (see section 5.2.2). Only hold the cells by the top or by the black light protection cap.



With turbidity values under 1 FNU/NTU, the measured value is strongly influenced by the cell and its alignment.

To increase measurement accuracy with turbidity values under 1 FNU/NTU, calibration in the 0.02 FNU/NTU standard and later measurement should take place in the same cell.

Measuring

For quick and easy measuring we recommend that you use marked cells (see section 4.3.1 PREPARING THE CELL).

If your cells are not marked you can determine the suitable position of the individual cells in the cell shaft while measuring.

- 1 Clean the cell (see section 5.2.2).
- 2 Rinse the cell:
Pour approximately 10 ml sample into the cell. Close the cell and rotate it several times before throwing the sample away.
- 3 Repeat the rinsing procedure twice more.

- 4 Fill the cell with the sample to be measured (approx. 15 ml). Close the cell with the black light protection cap.
- 5 Insert the cell (see section 4.2).
- 6 Align the marking on the cell cap with the marking at the cell shaft.
or
Determine the suitable position of the cell in the cell shaft (see DETERMINING A SUITABLE POSITION IN THE CELL SHAFT, page 15).
- 7 Press the **<START/ENTER (.) >** key.
Measurement starts. The measured value is displayed.

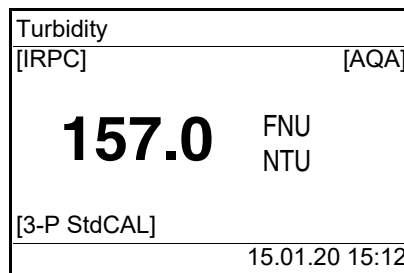

The measured value is automatically output to the interfaces (= AutoPrint).

- 8 Repeat the steps 2 to 8 for further samples.

Intelligent reproducibility and plausibility check (IRPC)

With the intelligent reproducibility and plausibility check (IRPC) a multiple measurement is carried out, evaluated and, by eliminating the outliers, the plausible measured value is indicated on the display. The intelligent reproducibility and plausibility check (IRPC) is active with all measurements. It is displayed in the upper status line [IRPC].

Display with measuring range overflow

If the measured value is outside the measuring range of the Turb® 750 IR, this is indicated on the display:

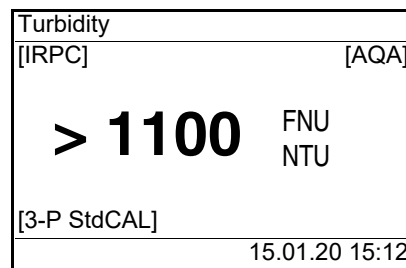

4.6.1 Settings for turbidity measurement

Overview

For turbidity measurements, the following settings are possible in the menu *Configuration / Turbidity*:

- *Calibration*
- *Resolution*
- *Reset*

Settings/functions

The settings are in the menu, *Configuration / Turbidity*. Move to the *Configuration* menu with the <MENU⁽⁷⁾> key.

Menu item	Setting	Explanation
<i>Calibration</i>	...	Settings and data in the menu <i>Calibration</i> (see section 4.7.1).
<i>Resolution</i>	0.01 0.001	Resolution of the FNU/NTU display for the range 0.01... 0.99 FNU/NTU
<i>Reset</i>		Reset all settings for the <i>Turbidity</i> measuring mode (see section 4.11.2)

4.7 Calibration

When to calibrate?

- Routinely within the framework of the company quality assurance
- When the calibration interval has expired
- With a temperature change

Calibration types and calibration standards

The following calibration types can be selected for calibration:

Calibration type	Standards (FNU/NTU)	Explanation
<i>3-P StdCAL</i>	1000 10.0 0.02	Guided calibration with three permanently set calibration standard solutions. The <i>3-P StdCAL</i> calibration is the recommended calibration type for most applications.

Calibration type	Standards (FNU/NTU)	Explanation
<i>QuickCAL</i>	10.0	<p>Guided calibration with a single calibration standard.</p> <p>With the <i>QuickCAL</i> calibration value, the calibration graph of the <i>3-P StdCAL</i> calibration in the lower measuring range is adjusted.</p> <p>The calibration is only successful if the measured value for the standard deviates from the value of the <i>3-P StdCAL</i> calibration by less than $\pm 50\%$.</p> <p>The measuring range for measurements with the <i>QuickCAL</i> calibration is limited to the lower range (see section 7.2 TURBIDITY).</p>
<i>FreeCAL</i>	2... 5	<p>Guided flexible calibration with 2 to 5 freely selectable calibration standards. The nominal values for the calibration standards are entered manually.</p> <p>The order of the entered nominal values corresponds to the order of the calibration standards during the calibration process.</p>

4.7.1 Settings for calibration

Settings

The settings are in the menu *Configuration / Turbidity / Calibration*. To switch to the *Configuration* menu, press the **<MENU⁽⁷⁾>** key.

Menu item	Possible setting	Explanation
<i>Calibr. record</i>	-	Display the calibration record of the last calibration.

Menu item	Possible setting	Explanation
<i>Calibr. type</i>	<i>3-P StdCAL</i> <i>FreeCAL</i> <i>QuickCAL</i>	The selected calibration type is used to calculate the current measured value. The active calibration type is indicated in the measured value display, and stored together with a measured value. When you start calibration with the <CAL⁽⁴⁾> key, it is always started with the selected calibration type.
<i>Standard</i> (only with <i>Calibr. type FreeCAL</i>)	<i>Number</i>	1... 5 Number of calibration standards for the <i>Calibr. type FreeCAL</i>
	<i>Standard 1</i> ... <i>Standard 5</i>	Here the nominal values are entered for all calibration standards
<i>Calibr. interval</i>	1... 999 d	Calibration interval for turbidity measurement (in days). If the calibration interval has expired, the meter reminds you to calibrate before each measurement.

4.7.2 Carrying out a calibration

Preparing the calibration

For quick and easy measuring we recommend that you use marked cells with the calibration standards (see section 4.3.1 PREPARING THE CELL).

If your cells are not marked you can determine the suitable position of the individual cells in the cell shaft while measuring.

Perform the following preparatory activities when you want to calibrate:

- 1 Select the calibration type (menu *Configuration / Turbidity / Calibr. type.*).



For *QuickCAL* calibration with the **<QuickCAL⁽¹⁾>** key, the setting of the *QuickCAL* calibration type and limitation of the measuring range are done automatically.

Carrying out a calibration (example: 3-P StdCAL)

- 2 Clean the cell (see section 5.2.2).
- 3 Insert the cell (see section 4.2).
- 4 Press the **<CAL (4) >** key.
The guided calibration with the selected calibration type starts. Follow the instructions on the display.

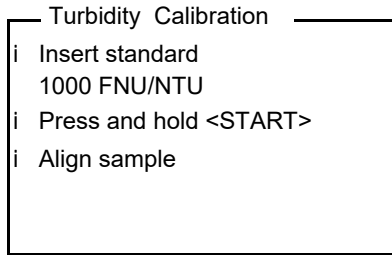

- 5 Insert the cell with the displayed calibration standard (here e.g. 1000 FNU/NTU) in the cell shaft (see section 4.2).
- 6 Align the marking on the cell cap with the marking at the cell shaft.
or
Determine the suitable position of the cell in the cell shaft (see DETERMINING A SUITABLE POSITION IN THE CELL SHAFT, page 15).

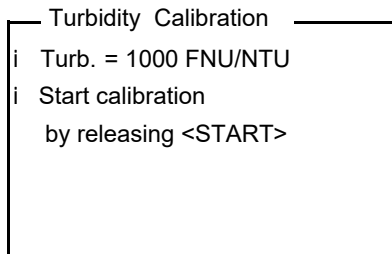

- 7 Release the **<START/ENTER (.) >** key.
Measurement of the calibration standard begins.



Before measuring the third calibration standard of 0.02 FNU/NTU you can exit the calibration with **<ESC>** at any time. The new calibration data are discarded. The old calibration data are used.

- 8 Repeat the steps 4 - 6 with the calibration standards 10.00 FNU/NTU and 0.02 FNU/NTU.
After measuring the 0.02 FNU/NTU calibration standard, the calibration result is displayed.
The calibration is complete.

- 9 Confirm the calibration result with **<START/ENTER (.) >**.
The calibration record is displayed.
- 10 Confirm the calibration record with **<START/ENTER (.) >**.
The display shows instructions for the first measurement.
The valid calibration is indicated on the display as a status, e.g. [3-P StdCAL].

```

— Turbidity —
i Insert sample
i Press and hold <START>
i Align sample

[3-P StdCAL]

```

Calibration record

At the end of each calibration procedure a calibration info (i symbol) and the calibration record is displayed.

For each calibration type the last calibration is stored in the calibration memory.

Display calibration data and output to interface

You can view the data of the last calibration on the display. Subsequently, you can download the displayed calibration data to the interface, e. g. to a printer or PC, with the **<PRT (8) >** key.

The calibration record of the last calibration is to be found under the menu item, *Configuration / Turbidity / Calibr. record*.

Sample printout of a record

```

15.01.20 16:13
Turb® 750 IR Ser. no. 12345678
Calibration Turbidity
Calibr. date 15.01.20 16:13:33
Calibr. interval 90 d
3-P StdCAL
Standard 1          1000 NTU
Standard 2          10.0 NTU
Standard 3          0.02 NTU

```

4.8 Analytical quality assurance (AQA)

4.8.1 General information

Target of the analytical quality assurance (AQA) is to guarantee correct and precise measurement results.

The monitoring includes a check routine that has to be successfully repeated by the user within a certain period (AQA-interval).



The AQA monitoring is not enabled in the delivery condition.

AQA in the measured value documentation

All measured values that are measured after the test was passed and within the AQA interval are given the label [AQA] in the measured value documentation.

AQA test standards

An AQA test standard, e.g. 10 FNU/NTU is required for the turbidimeter monitoring.



Note the expiry date of the AQA test standards. When you use new AQA test standards, it is always required to check the values in the turbidimeter. Adjust the values at the turbidimeter as necessary.

Overview of the turbidimeter monitoring

The turbidimeter monitoring (AQA) includes the following parts:

- Do the settings in the menu.
 - Specify the Intervall
 - Specify the tolerance
 - Enter the nominal values and lot IDs for each AQA test standard
- Carry out the AQA check. The turbidimeter compares the results with the nominal values while taking into account the selected tolerance ranges.

4.8.2 Settings for quality assurance (AQA)

The settings are in the menu, *Configuration / Turbidity / AQA*. Move to the

Configuration menu with the <MENU ⁽⁷⁾ > key.

— AQA	
AQA	On
AQA protocol	
AQA tolerance	10 %
AQA interval	90 d
Standard	10.0 FNU/NTU

Menu item	Possible setting	Explanation
AQA	On Off	Switch on or off the AQA checks for the meter.
AQA protocol	-	Displays the AQA protocol of the last check.
AQA tolerance	1... 10 ... 100 %	Maximum allowed deviation from the nominal value at which an AQA check will be successful.
AQA interval	1... 90 .. 999 d	Interval for the duration between two AQA tests (in days). If there is a valid AQA test, the [AQA] indicator appears on the display and in the measured value memory. When the AQA interval has expired, the [AQA] indicator is no longer displayed.
Standard	10 FNU/NTU	AQA test standard for the AQA check

4.8.3 Carrying out the AQA check

The AQA check includes the check with all AQA test standards that were activated in the menu *Configuration / Turbidity / AQA / Standard*.

Preparing the AQA check

For quick and easy measuring we recommend that you use marked cells with the required AQA test standards (see section 4.3.1 PREPARING THE CELL).

If your cells are not marked you can determine the suitable position of the individual cells in the cell shaft while measuring.

Perform the following preparatory activities when you want to carry out an

AQA check:

- 1 Select the AQA test standard (menu *Configuration / Turbidity / AQA.*).
- 2 Clean the cell (see section 5.2.2).
- 3 Insert the cell (see section 4.2).

Carrying out the AQA check

- 1 Press the **<AQA (2) >** key.
The guided AQA check with the selected AQA test standard begins. Follow the instructions on the display.

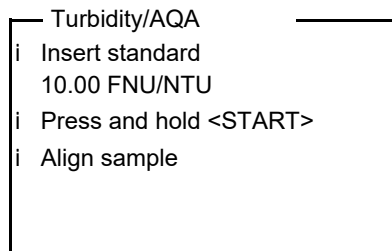

- 2 Insert the cell with the displayed AQA test standard (here e.g. 10.00 FNU/NTU) in the cell shaft (see section 4.2).
- 3 Align the marking on the cell cap with the marking at the cell shaft.
or
Determine the suitable position of the cell in the cell shaft (see DETERMINING A SUITABLE POSITION IN THE CELL SHAFT, page 15).

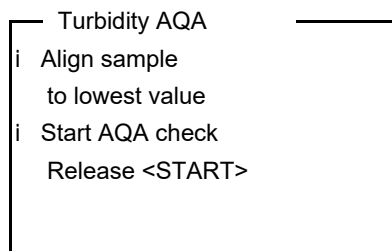

- 4 Release the **<START/ENTER (·) >** key.
The measurement of the AQA test standard starts.
- 5 Measure further AQA test standards as necessary.
The test is passed when all AQA test standards have been successfully measured.
AQAThe presence of a valid AQA check is indicated by a status display indicator, e.g. [AQA].

AQA protocol

An AQA protocol is displayed after the check. AQA Subsequently, you can download the AQA protocol to the interface, e. g. to a printer or PC, with the

<PRT ⁽⁸⁾ > key.

Sample printout:

```

15.01.20          12:30
Turb® 750 IR/T   Ser. no. 12012345
AQA Turbidity
AQA date          15.01.20 12:30:40
AQA tolerance     2 %
AQA interval      90 d
3-P StdCAL
Calibr. date      15.01.20 08:57:45
Standard 1        10.0 NTU
Status 1          OK

```



Go to *Configuration / Turbidity / AQA /* to view the last AQA protocol.

4.9 Memory

The meter has 2500 storage locations for measurement datasets.

You can transmit measured values (datasets) to the data memory with the <STO ⁽⁰⁾ > key.

Each data storing process transmits the current dataset to the interface at the same time.

The number of memory locations that are still free is displayed in the *Store* menu. The number of memory locations that are occupied is displayed in the *System / Measured value memory* menu.

Measurement dataset

A complete dataset consists of:

- Date/time
- ID number (ID)
- Measured value

4.9.1 Storing measurement datasets

Proceed as follows to transmit to the data memory and simultaneously output

to the interface a measurement dataset:

- 1 Press the **<STO⁽⁰⁾>** key.
The *Store* display appears.

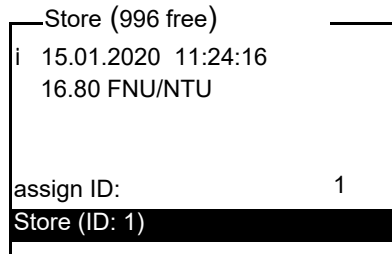

- 2 Using **<▲>**, **<▼>**, **<START/ENTER^(.)>** and the number keys, change and confirm the ID number (*ID*) as necessary (0 ... 999).
- 3 Using **<START/ENTER^(.)>** or **<STO⁽⁰⁾>**, confirm *Store*.
The dataset is stored. The meter switches to the measured value display.



A measurement dataset is quickly stored by twice pressing **<STO⁽⁰⁾>**. It is stored with the ID last set.

If the memory is full

You can erase the entire memory (see section 4.9.5), or overwrite the oldest dataset with the next storing procedure. A security prompt appears before a dataset is overwritten.

4.9.2 Filtering measurement datasets

The functions to display and download stored measurement datasets (see section 4.5.1) refer to all stored measurement datasets that correspond to the specified filter criteria.

The settings are in the menu, *Configuration / System / Measured value memory / Data filter*.

Move to the *Configuration* menu with the **<MENU** ⁽⁷⁾ **>** key.

Data filter	Menu item	Setting/function	Explanation
<i>Filter</i>		<i>No filter</i>	Filter criteria: Data filter switched off
		<i>ID</i>	Selection according to ID number
		<i>Date</i>	Selection according to period
		<i>ID + Date</i>	Selection according to period and ID number
	<i>ID</i>		Entry of filter criteria These menu items are made visible by selecting the filter criteria in the <i>Filter</i> menu.
	<i>Date</i>		

4.9.3 Displaying measurement datasets

You can read out stored datasets to the display. Only those datasets are displayed that correspond to the selected filter criteria (see section 4.9.2).

Start reading out the data to the display in the menu, *Configuration / System / Measured value memory / Display*.

Representation of a dataset

```

15.01.2020 11:24:16
ID: 1
16.80 FNU/NTU
[QuickCAL]
09.01.2020 07:54:53
i Scroll with UP DWN

```

Further datasets that correspond to the filter criteria are displayed with the **<▲>** **<▼>** keys.

Quitting the display

To quit the display of stored measurement datasets, you have the following options:

- Switch directly to the measured value display with **<M** ⁽⁹⁾ **>** (short pressure).
- Leave the display and switch to the superordinate menu with **<ESC>** or **<START/ENTER** ^(.) **>**.

4.9.4 Outputting measurement datasets to the interfaces

You can output stored datasets to the interface. Only those datasets are downloaded that correspond to the selected filter criteria (see section 4.9.2).

The datasets are downloaded in the specified output format (see section 4.10.5).

The output of the data to the interface is started in the menu, *Configuration / Measured value memory / RS232 download*.

4.9.5 Erasing stored measurement datasets

You can erase the stored measurement datasets altogether if you no longer need them.

Erasing all measurement datasets is done in the menu, *Configuration / System / Measured value memory / Delete*.



Erasing individual datasets is not possible. If all memory locations are occupied, however, it is possible to overwrite the oldest dataset at a time. A security prompt appears before a dataset is overwritten.

4.10 Transmitting data

To transmit data via the interfaces, first establish a connection to a PC or printer (see section 4.10.1).

With the PC software Turb® Data you can, without further configuration, transmit or save measurement and calibration data for GLP-compliant data management to Turb® Data or transmit them to Excel and thus to LIMS.

With the MultiLab® Importer (an add-in for Microsoft Excel) you can transmit data from the meter directly to an open Excel sheet (see section 4.10.3).

The connection to a printer or terminal program has to be configured so data can be safely transmitted (see section 4.10.4).

4.10.1 Establishing the connection to a PC

Via the USB interface you can transmit and evaluate data to a PC.

System? requirements (PC)

Microsoft Windows PC with one of the following operating systems:

- Windows 7
- Windows 8

– Windows 10.

1 Connect the Turb[®] 750 IR/T to the PC via the USB-B interface with the enclosed USB cable.
Microsoft Windows automatically searches a suitable USB driver.

2 If a suitable USB driver was found:

- Install the driver.
Follow the Windows installation instructions.

If no suitable USB driver was found:

- Insert the supplied CD-ROM into the CD drive of your PC.
- Install the driver.
Follow the Windows installation instructions.

The connection to the PC is established. The data can be transferred to the PC:

- via the PC software Turb[®] Data (see section 4.10.2)
- via the MultiLab[®] Importer (see section 4.10.3)
- via a terminal program (see section 4.10.6).



The meter is listed as a virtual COM interface among the connections in the Windows instrument manager.

Only one cable may be connected to an interface (RS232 or USB) of the meter at a time.

4.10.2 Data transmission with the PC software Turb[®] Data

With the PC software Turb[®] Data you can transmit and save to the Turb[®] Data any measurement- and calibration data for GLP compliant data management (menu item *Datei / Speichern unter... / *.csv* (CSV format)) or transmit and save to Excel (menu item *Datenaustausch / Export (.xls)*) and thus transfer to LIMS.

- 1 Establish the connection to a PC (see section 4.10.1).
- 2 Transmit data (see operating manual of the PC software Turb[®] Data).

4.10.3 Data transmission with the Excel add-in MultiLab[®] Importer



Set the CSV output format for datasets at the Turb[®] 750 IR/T. It is selected in the menu, *Configuration / System / Interface / Output format* (see section 4.10.5 ESTABLISHING THE CONNECTION TO A PRINTER).

- 1 Establish the connection to a PC (see section 4.10.1).
- 2 Establish a data connection (see operating manual MultiLab[®] Importer).
- 3 Transmit data (see section 4.10.6).

4.10.4 Configuration for the data transmission to a terminal program

Via the USB interface you can also transmit data to a PC with the aid of a so-called terminal program.

- 1 Establish the connection to a PC (see section 4.10.1).
- 2 Determine the output format of datasets at the Turb[®] 750 IR/T (see section 4.10.5 ESTABLISHING THE CONNECTION TO A PRINTER
It is selected in the menu, *Configuration / System / Interface / Output format*.
Examples of the output formats (see section 4.10.6)
- 3 Configure the USB interface at the Turb[®] 750 IR/T and the terminal program.
The transmission data specified in the Turb[®] 750 IR/T and terminal program have to match.
 - USB interface (see section 4.5.3).
 - Terminal (see operating manual of your terminal).

Transmission data:

Baud rate	can be selected from: 1200, 2400, 4800, 9600, 19200
Handshake	none
Parity	none
Data bits	8
Stop bits	1

- 4 Transmit data (see section 4.10.6).
Examples of transmitted data (see section 4.10.7)

4.10.5 Establishing the connection to a printer

Via the RS 232 interface, you can transmit data to an external printer.

Suitable printers

- P3002 (see section 8 ACCESSORIES AND OPTIONS)
- P3001 (no longer available as accessory)

Socket assignment (RS232)

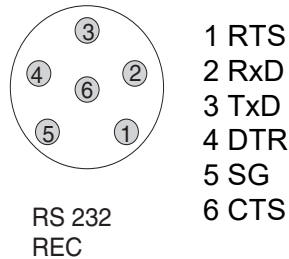

- 1 Connect the RS232 interface to the external printer with the AK540/S cable.



Only one cable may be connected to an interface (RS232 or USB) at a time.

The Turb[®] 750 IR/T is pre-configured for the connection of the printer.

- 2 For error-free data transmission:
The RS232 interface of the Turb[®] 750 IR/T and the printer have to be set to the same transmission speed (*Baud rate*).
 - The baud rate of the Turb[®] 750 IR/T is selected in the menu *Configuration / System / Interface / Baud rate*.
 - The setting of the baud rate of the printer and the default setting are in the documentation of your printer.
- 3 Selecting the output format of datasets (Turb[®] 750 IR/T)
It is selected in the menu, *Configuration / System / Interface / Output format*.
Examples of the output formats (see section 4.10.7)
- 4 Transmitting data (see section 4.10.6).
Examples of transmitted data (see section 4.10.7)

4.10.6 Starting the data transmission at the Turb[®] 750 IR/T

(at MultiLab® Importer, printer, terminal program



Measured values are automatically output to the interfaces (= AutoPrint).

With a printer connected or a connection to a terminal program existing, you can transmit data in the following ways:

Individual data

(e.g. calibration protocol, AQA protocol, measured value)

- Display the data and press <PRT (8) >. The data being shown on the display are transmitted to the interface.
- Simultaneously with every manual storage process.

Stored measured values

- Display the saved data and press <PRT (8) >.
- All datasets according to the filter criteria (section 4.5) via the RS232/USB output function (see section 4.9.2.).

4.10.7 Examples of data transmitted (printer, terminal program)

The data are output according to the selected output format.

The ASCII output format delivers formatted datasets.

Example; output format ASCII

```

Turb® 750 IR Ser. no. 12345678
15.01.20 09:56:20
ID: 1
10.1 NTU [AQA]
[3-P StdCAL] : 15.01.20 08:57:45

-----

Turb® 750 IR Ser. no. 12345678
15.01.20 08:48:08
ID: 1
26.1 NTU [AQA]
[3-P StdCAL] : 15.01.20 08:57:45

-----

etc...
```

**Example,
output format CSV**

The CSV output format delivers datasets separated by ";".
The data are output in the following order:

1	2	3	4	5	6	7	8	9	10
↓	↓	↓	↓	↓	↓	↓	↓	↓	↓
<pre>15.01.20;15:06:49;1;26.5;NTU;VALID;[AQA][3-P StdCAL];15.01.20;08:67:47 15.01.20;16:06:49;1;16.5;NTU;VALID;[AQA][3-P StdCAL];15.01.20;08:67:47</pre>									

- 1 Date of storing
- 2 Time of storing
- 3 Selected ID
- 4 Measured value or
Upper/lower measuring range limit
(only with measured value status, OFL/UFL)
- 5 Unit of the measured value
- 6 Measured value status
 - * VALID: Measured value valid
 - * INVALID: Measured value invalid
 - * UFL: Measured value below the lower measuring range limit
 - * OFL: Measured value above the upper measuring range limit
- 7 AQA status
 - * [AQA]: a valid AQA check is available
 - * : no valid AQA check is available
- 8 Calibration status: Calibration type that was selected for the measurement
- 9 Calibration status: Date of calibration
- 10 Calibration status: Time of calibration



If the connected external printer does not print, please check whether the same baud rate is set at the Turb[®] 750 IR/T and printer.

4.11 Reset

You can reset (initialize) all system and measurement settings.

4.11.1 Resetting the system settings

With the *System / Reset* function, all resettable settings are reset.

- Settings for *Turbidity* (see section 4.11.2)
- System settings

System setting	Default settings
<i>Language</i>	<i>English</i>
<i>Baud rate</i>	4800 Baud
<i>Output format</i>	ASCII
<i>Illumination</i>	<i>Auto off</i>
<i>Contrast</i>	50 %
<i>Brightness</i>	50 %
<i>Switchoff time</i>	30 min
<i>Beep</i>	<i>On</i>

4.11.2 Resetting turbidimeter settings

With the *Turbidity / Reset* function, all turbidimeter settings are reset.

Calibration ?set- tings

Setting	Default settings
<i>Calibr. interval</i>	90 d
<i>Calibr. type</i>	3-P StdCAL
<i>FreeCAL Number</i>	2
<i>FreeCAL Standard 1</i>	10 FNU/NTU

AQA settings

Setting	Default settings
<i>AQA tolerance</i>	2 %
<i>AQA interval</i>	90 d
<i>Standard</i>	10 FNU/NTU

Display settings?

Setting	Default settings
<i>Resolution</i>	0.01

4.12 Meter information

The following meter information is listed in the *Configuration / Info* menu:

- Model designation
- Software version
- Series number of the meter

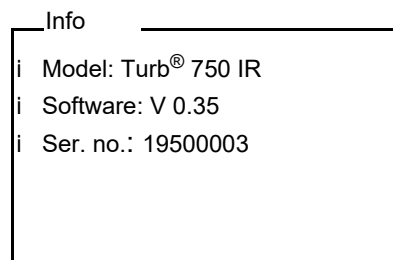

4.13 Software update

With a software update you obtain the current instrument software (see appendix).

The current software version can be found on the Internet at www.xylemanalytics.com.

The proceeding for updating the software is given in the appendix (see FIRMWARE UPDATE).

5 Maintenance, cleaning

5.1 Maintenance

The meter is almost maintenance-free.

The only maintenance task is replacing the batteries.

Inserting/exchanging the batteries

1. Open the battery compartment (1) on the underside of the meter.

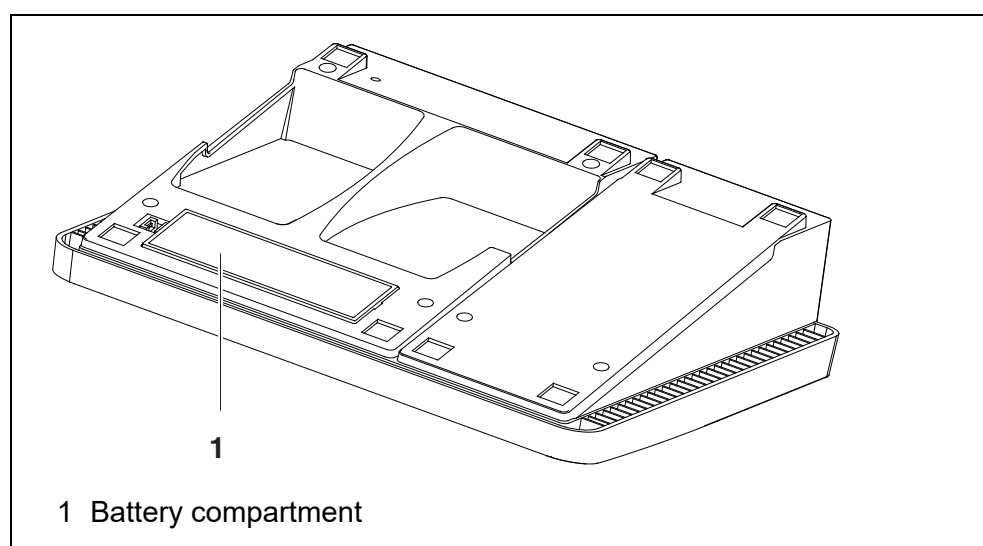

NOTE

Make sure that the poles of the batteries are positioned correctly. The \pm signs on the batteries must correspond to the \pm signs in the battery compartment.

2. Place four batteries (type Mignon AA) in the battery compartment.
3. Close the battery compartment (1).
4. Set the date and time (see section 4.5.5).

5.2 Cleaning

Occasionally wipe the outside of the measuring instrument with a damp, lint-free cloth. Disinfect the housing with isopropanol as required.

NOTE

The housing components are made of synthetic materials (polyure-

thane, ABS and PMMA). Thus, avoid contact with acetone and similar detergents that contain solvents. Remove any splashes immediately.

5.2.1 Cleaning the cell shaft

If liquid is in the cell shaft (e.g. due to a spilled cell), clean the cell shaft as follows:

- 1 Switch the Turb[®] 750 IR/T off and pull out the power plug.
- 2 Rinse the cell shaft with distilled water.

5.2.2 Cleaning the cells

Cells have to be clean, dry, and free of fingerprints. Therefore, clean them regularly:

- 1 Clean the cells inside and out with hydrochloric acid or laboratory soap.
- 2 Rinse several times with distilled water.
- 3 Let them dry in the air.
- 4 Only hold the cells by the top or by the light protection cap so that the optical path is not impaired.
- 5 Before measuring, clean the cell with the enclosed cleaning cloth.

5.3 Packing

This meter is sent out in a protective transport packing. We recommend: Keep the packing material. The original packing protects the meter against damage during transport.

6 What to do if...

6.1 General information

Display, LoBat	Cause – Batteries almost empty	Remedy – Insert new batteries
Meter does not react to keystroke	Cause – Software error – Operating condition undefined or EMC load unallowed	Remedy – Processor reset: Press the < START/ENTER (.) > and < PRT ⁽⁸⁾ > keys simultaneously.
Error message i AQA not activated!	Cause – The AQA function was not activated.	Remedy – Activate the AQA-check (see section 4.8.2 SETTINGS FOR QUALITY ASSURANCE (AQA))
Error message, Error 0, 8, 16, 16384	Cause – Instrument error	Remedy – Repeat measurement – Meter defective, contact the service department
You want to know which software version is in the meter	Cause – E.g., a question by the service department	Remedy – Switch on the meter. – Open the menu <i>Configuration/ System/ Info</i> . The instrument data are displayed.

6.2 Turbidity

Error message
Measured values
obviously incor-
rect

Cause	Remedy
– Cell not correctly inserted	– Lock the cell into place
– Cell contaminated	– Clean the cell
– Calibration too old	– Carry out calibration

Measured value
display
< 0.01 FNU/NTU

Cause	Remedy
– Calibration defective	– Carry out calibration
– Measured value outside the measuring range	– Not possible

7 Technical data

7.1 General data

Dimensions	Approx. 290 x 190 x 80 mm	
Weight	Approx. 1.0 kg	
Mechanical structure	Type of protection	IP 43
Electrical safety	Protective class	III
Test certificates	CE	
Ambient conditions	Storage	-25 °C... +65 °C
	Operation	+5 °C ... +40 °C
	Admissible relative humidity	Yearly mean: < 75 % 30 days/year: 95 % Other days: 85 %
Power supply	Batteries	4 x 1.5 V alkali-manganese batteries, type AA
	Power pack	ShenZhen RiHuiDa Power Supply Co Ltd RHD20W090150 Input: 100... 240 V ~ / 50... 60 Hz / 400 mA Output: 9 V = / 1.5 A Connection max. overvoltage category II
	Primary plugs	Primary plugs included in the scope of delivery: Euro, US, UK and Australian.
Serial interface (printer)	Connection of the cable AK 540/B or AK 540/S	
	Baud rate	Adjustable: 1200, 2400, 4800, 9600, 19200 baud
	Type	RS232
	Data bits	8
	Stop bits	1
	Parity	None
	Handshake	RTS/CTS
	Cable length	Max. 15 m

USB interface (PC)	Type	USB 1.1 USB-B (Device), PC
	Baud rate	Adjustable: 1200, 2400, 4800, 9600, 19200 baud
	Data bits	8
	Stop bits	1
	Parity	None
	Handshake	None
	Cable length	max. 3 m (9.843 feet)

Guidelines and norms used	EMC	EC directive 2014/30/EC EN 61326-1 FCC Class A
	Meter safety	EC directive 2014/35/EC EN 61010-1
	IP protection class	EN 60529

7.2 Turbidity

7.2.1 Turb[®] 750 IR

Measuring principle Nephelometric measurement according to DIN EN ISO 7027

Light source Infrared LED

Calibration	3-P StdCAL	QuickCAL	FreeCAL
Measuring range depending on the calibration type	0.01... 1100 FNU/NTU	0 - 40 FNU/NTU	lowest - highest standard FNU/NTU

Resolution with the setting *Resolution* 0.001

In the range 0.001... 0.999 FNU/ NTU	max. 0,001 FNU/NTU
In the range 1.00... 9.99 FNU/NTU	max. 0.01 FNU/NTU

	with the setting <i>Resolution</i> 0.01	
	In the range 0.01... 9.99 FNU/NTU	max. 0.01 FNU/NTU
	irrespective of the setting <i>Resolution</i>	
	In the range 10.0... 99.9 FNU/NTU	max. 0.1 FNU/NTU
	In the range 100... 1100 FNU/NTU	max. 1 FNU/NTU
Accuracy	In the range 0... 1100 FNU/NTU	± 2 % of the measured value or ± 0.01 FNU/NTU
Repeatability	0.5% of the measured value	
Response time	4 seconds	
Minimum filling volume of the cell	15 ml	

7.2.2 Turb® 750 T

Measuring principle	Nephelometric measurement according to US EPA 180.1		
Light source	White light tungsten lamp		
Calibration	3-P StdCAL	QuickCAL	FreeCAL
Measuring range depending on the calibration type	0.01... 1100 NTU	0 - 40 NTU	lowest - highest standard NTU
Resolution	with the setting <i>Resolution</i> 0.001		
	In the range 0.001... 0.999 NTU	max. 0.001 NTU	
	In the range 1.00... 9.99 NTU	max. 0.01 NTU	
	with the setting <i>Resolution</i> 0.01		
	In the range 0.01... 9.99 NTU	max. 0.01 NTU	

	irrespective of the setting <i>Resolution</i>	
	In the range 10.0... 99.9 NTU	max. 0.1 NTU
	In the range 100... 1100 NTU	max. 1 NTU
Accuracy	In the range 0... 500 NTU	± 2 % of the measured value or ± 0.01 NTU
	In the range 500... 1100 NTU	± 3% of measured value
Repeatability	1% of the measured value	
Response time	7 seconds	
Minimum filling volume of the cell	15 ml	

8 Accessories and options

Accessories	Description	Model	Order no.
	3 replacement cells, 28 x 60 mm	LKS28-Set	251 302
	Calibration set for Turb 430/750 IR	Kal.Kit Turb 430/750 IR	600 560
	Calibration set for Turb 430/750 T	Kal.Kit Turb 430/750 T	600 561
	Thermoprinter*	P3002	250 049

* A connection cable is required to connect the printer (see below)

Connection cable (PC)	Description	Model	Order no.
	USB cable (USB-A to USB-B micro)	Included in the scope of delivery, Specialist shops	

Connection cable (printer)	Description	Model	Order no.
	Cable	AK 540/S	902 843

9 Firmware update

You can find available firmware update files for your meter on the Internet. With the "Firmware Update " program and a PC you can update the firmware of the Turb[®] 750 IR/T to the newest version.

For the update you have to connect the meter to a PC.

For the update via the USB-B interface, the following is required:

- a free USB interface (virtual COM port) on the PC
- the driver for the USB interface (on the enclosed CD-ROM)
- the USB cable (included in the scope of delivery of the Turb[®] 750 IR/T).

- 1 Install the downloaded firmware update on a PC.
An update folder is created in the Windows start menu.
If an update folder already exists for the meter (or meter type), the new data are displayed there.
- 2 In the windows start menu, open the update folder and start the firmware update program for the meter
- 3 Using the USB interface cable, connect the Turb[®] 750 IR/T to a USB interface (virtual COM port) of the PC.
- 4 Switch on the Turb[®] 750 IR/T.
- 5 In the firmware update program, start the update process with OK.
- 6 Follow the instructions of the firmware update program.
During the programming process, a corresponding message and a progress bar (in %) are displayed.
The programming process takes up to 15 minutes. A terminatory message is displayed after a successful programming process. The firmware update is completed.
- 7 Disconnect the Turb[®] 750 IR/T from the PC.
The Turb[®] 750 IR/T is ready for operation again.

After switching the meter off and on you can check whether the meter has taken over the new software version (menu *Configuration System Info*).

10 Disposal

Handle and dispose of all waste in compliance with local laws and regulations.

EU only: Correct disposal of this product — WEEE Directive on waste electrical and electronic equipment

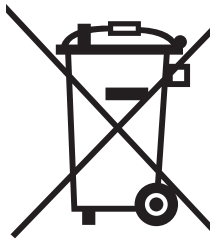

This marking on the product, accessories or literature indicates that the product should not be disposed of with other waste at the end of its working life.

To prevent possible harm to the environment or human health from uncontrolled waste disposal, please separate these items from other types of waste and recycle them responsibly to promote the sustainable reuse of material resources.



Waste from electrical and electronic equipment can be returned to the producer or distributor.

EU only: Correct disposal of batteries in this product

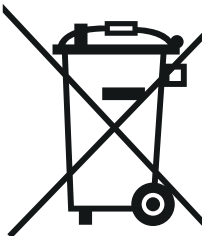

This marking on the battery, manual or packaging indicates that the batteries in this product should not be disposed of with other waste at the end of its working life. Where marked, the chemical symbols Hg, Cd or Pb indicate that the battery contains mercury, cadmium or lead above the reference levels in Directive 2006/66/EC. If batteries are not properly disposed of, these substances can cause harm to human health or the environment.

To protect natural resources and to promote material re-use, please separate batteries from other types of waste and recycle them through your local, free battery return system.

11 Lists

This chapter provides additional information and orientation aids.

Abbreviations

The list of abbreviations explains the indicators and the abbreviations that appear on the display and in the manual.

Specialist terms

The glossary briefly explains the meaning of the specialist terms. However, terms that should already be familiar to the target group are not described here.

Abbreviations

Cal	Calibration
d	Day
h	Hour
j	Year
LoBat	Batteries almost empty (Low battery)
m	Month
s	Second
S	Slope (internat. k)
SELV	Safety Extra Low Voltage
<i>Slp.</i>	Slope determined with calibration

Glossary

Resolution	Smallest difference between two measured values that can be displayed by a meter.
Adjusting	To manipulate a measuring system so that the relevant value (e.g. the displayed value) differs as little as possible from the correct value or a value that is regarded as correct, or that the difference remains within the tolerance.
Calibration	Comparing the value from a measuring system (e. g. the displayed value) to the correct value or a value that is regarded as correct. Often, this expression is also used when the measuring system is adjusted at the same time (see adjusting).
Cell	Vessel that takes a liquid sample for measurement.
LED	Light Emitting Diode LEDs are used as the light source in the Turb® 750 IR/T.
Measuring system	The measuring system comprises all the devices used for measuring, e. g. measuring instrument and probe. In addition, there is the cable and possibly an amplifier, terminal box and armature.
Measured parameter	The measured parameter is the physical dimension determined by measuring, e. g. pH, conductivity or DO concentration.
Test sample	Designation of the test sample ready to be measured. Normally, a test sample is made by processing the original sample. The test sample and original sample are identical if the test sample was not processed.
Measured value	The measured value is the special value of a measured parameter to be determined. It is given as a combination of the numerical value and unit (e. g. 3 m; 0.5 s; 5.2 A; 373.15 K).
Molality	Molality is the quantity (in Mol) of a dissolved substance in 1000 g solvent.
Reset	Restoring the original condition of all settings of a measuring system.
Standard solution	The standard solution is a solution where the measured value is known by definition. It is used to calibrate a measuring system.

12 Index

A

Air	16
Analytical quality assurance (AQA)	36
AQA	36

B

Battery compartment	11, 50
---------------------------	--------

C

Calibration	31
Calibration points and measuring ranges ...	31
Cleaning	50
Connecting sensors	8
Connectors	8

D

Data filter	41
Data memory	26
Dataset	39
Date and time	19, 21, 28
Default settings	
System settings	47
Turbidimeter	48
Display	8, 27
Display illumination	8

F

Filter	41
Firmware update	59

I

Initial commissioning	12
Initialize	47
Inserting a cell	13
Interface	28
IRPC	30

K

Keys	7
------------	---

M

Measured value display	16
Measurement data memory	39
Measurement dataset	39

Measuring range exceeded	30
Menus (navigation)	16
Messages	17

N

Navigation	16
------------------	----

O

Operating modes	16
-----------------------	----

R

Reset	47
RS232 socket assignment	45

S

Scope of delivery	11
Storing in memory	39
Switching on	13
System settings	26

T

Turbidity	29
-----------------	----

Xylem |'zīləm|

- 1) The tissue in plants that brings water upward from the roots;
- 2) a leading global water technology company.

We're a global team unified in a common purpose: creating advanced technology solutions to the world's water challenges. Developing new technologies that will improve the way water is used, conserved, and re-used in the future is central to our work. Our products and services move, treat, analyze, monitor and return water to the environment, in public utility, industrial, residential and commercial building services settings. Xylem also provides a leading portfolio of smart metering, network technologies and advanced analytics solutions for water, electric and gas utilities. In more than 150 countries, we have strong, long-standing relationships with customers who know us for our powerful combination of leading product brands and applications expertise with a strong focus on developing comprehensive, sustainable solutions.

For more information on how Xylem can help you, go to www.xylem.com.



Service and Returns:

Xylem Analytics Germany
Sales GmbH & Co. KG
WTW
Am Achalaich 11
82362 Weilheim
Germany

Tel.: +49 881 183-325
Fax: +49 881 183-414
E-Mail wtw.rma@xylem.com
Internet: www.xylemanalytics.com



Xylem Analytics Germany GmbH
Am Achalaich 11
82362 Weilheim
Germany

